

**Volt** redüktör

	MOTOR	K	K1	N	N1
<b>D 172</b> <b>D 173</b>	63M	304,25	374,25	125	103
	71M	341	421	140	112
	80M	352,5	442,5	158,5	130
	90S	418,5	518,5	178	138
	90L	450,5	550,5	178	138
	100S	454	559	197	149,5
	100L	491,5	596,5	197	149,5
	112M	480	590	219	165,5

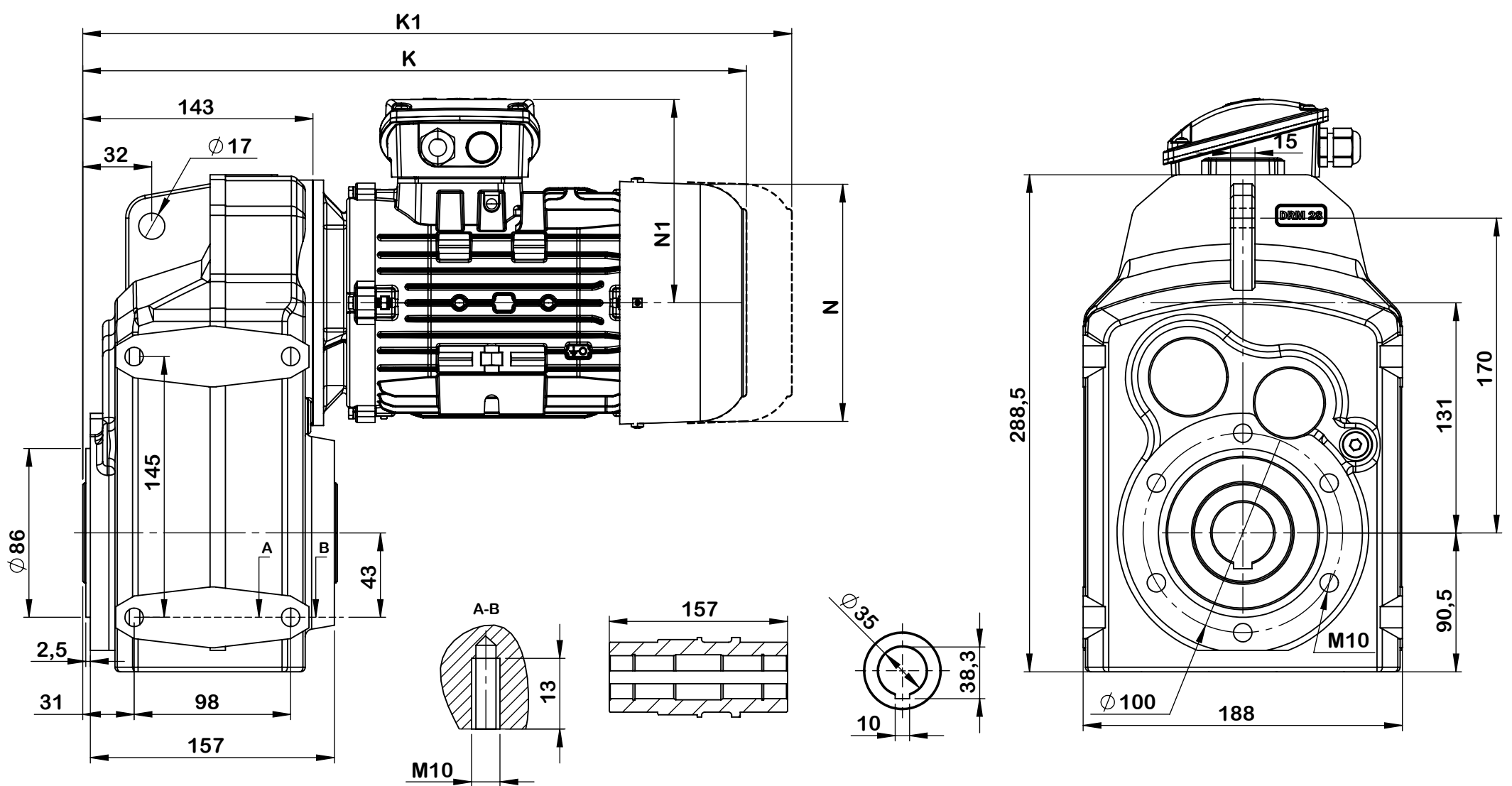

**Volt** redüktör

	MOTOR	K	K1	N	N1
<b>D 272</b> <b>D 273</b>	63M	336,25	406,25	125	103
	71M	373	453	140	112
	80M	384,5	474,5	158,5	130
	90S	450,5	550,5	178	138
	90L	482,5	582,5	178	138
	100S	486	591	197	149,5
	100L	523,5	628,5	197	149,5
	112M	512,5	622,5	219	165,5

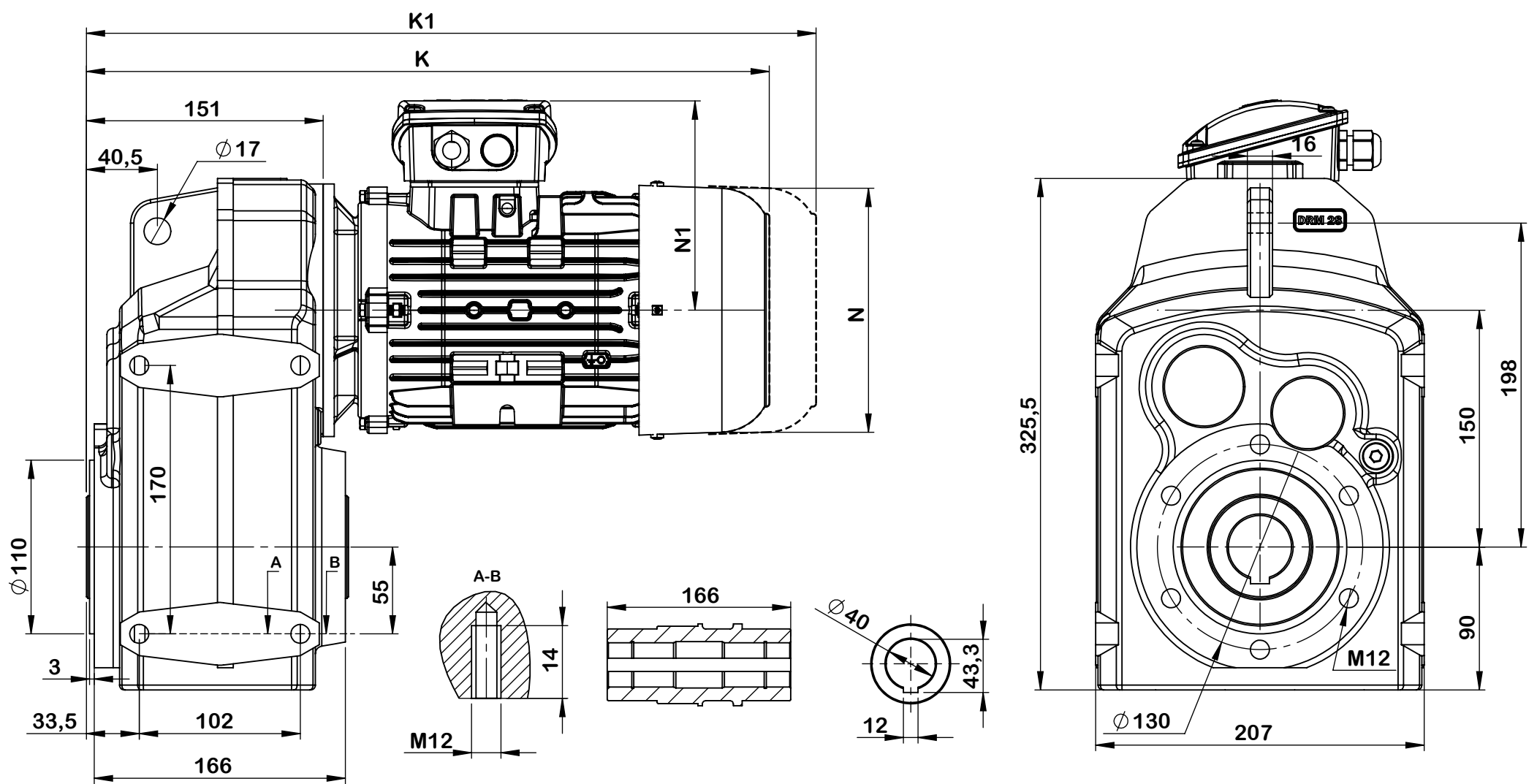

**Valt** redüktör

	MOTOR	K	K1	N	N1
<b>D 282</b> <b>D 283</b>	71M	391,5	471,5	140	103
	80M	395,5	485,5	158,5	130
	90S	458,5	558,5	178	138
	90L	490,5	590,5	178	138
	100S	494	599	197	149,5
	100L	531,5	636,5	197	149,5
	112M	513	623	219	165,5
	132S	562,5	697,5	258,5	186,5
	132M	600,5	735,5	258,5	186,5

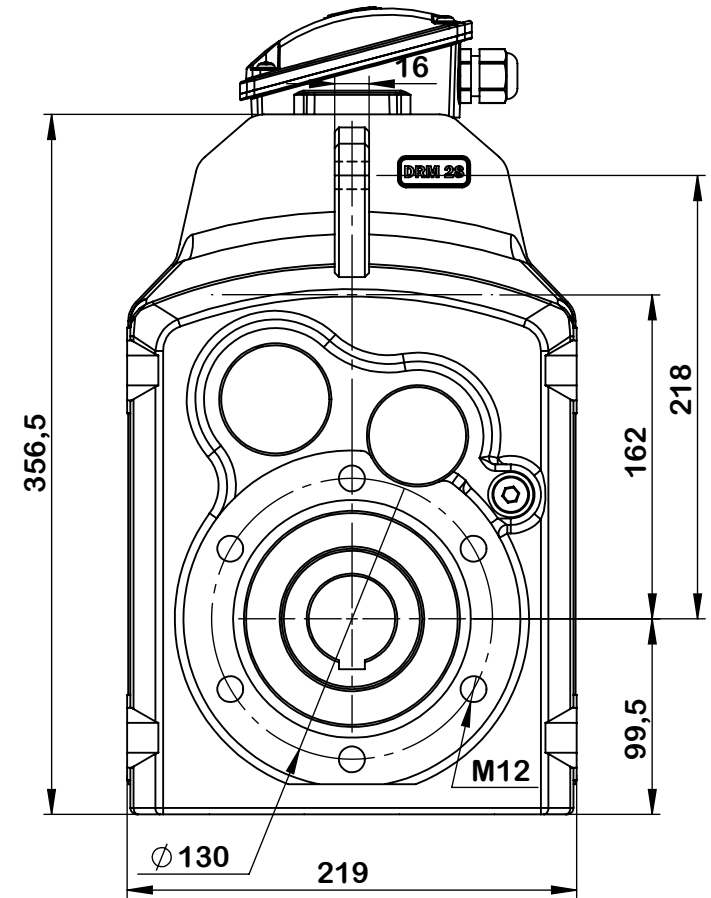
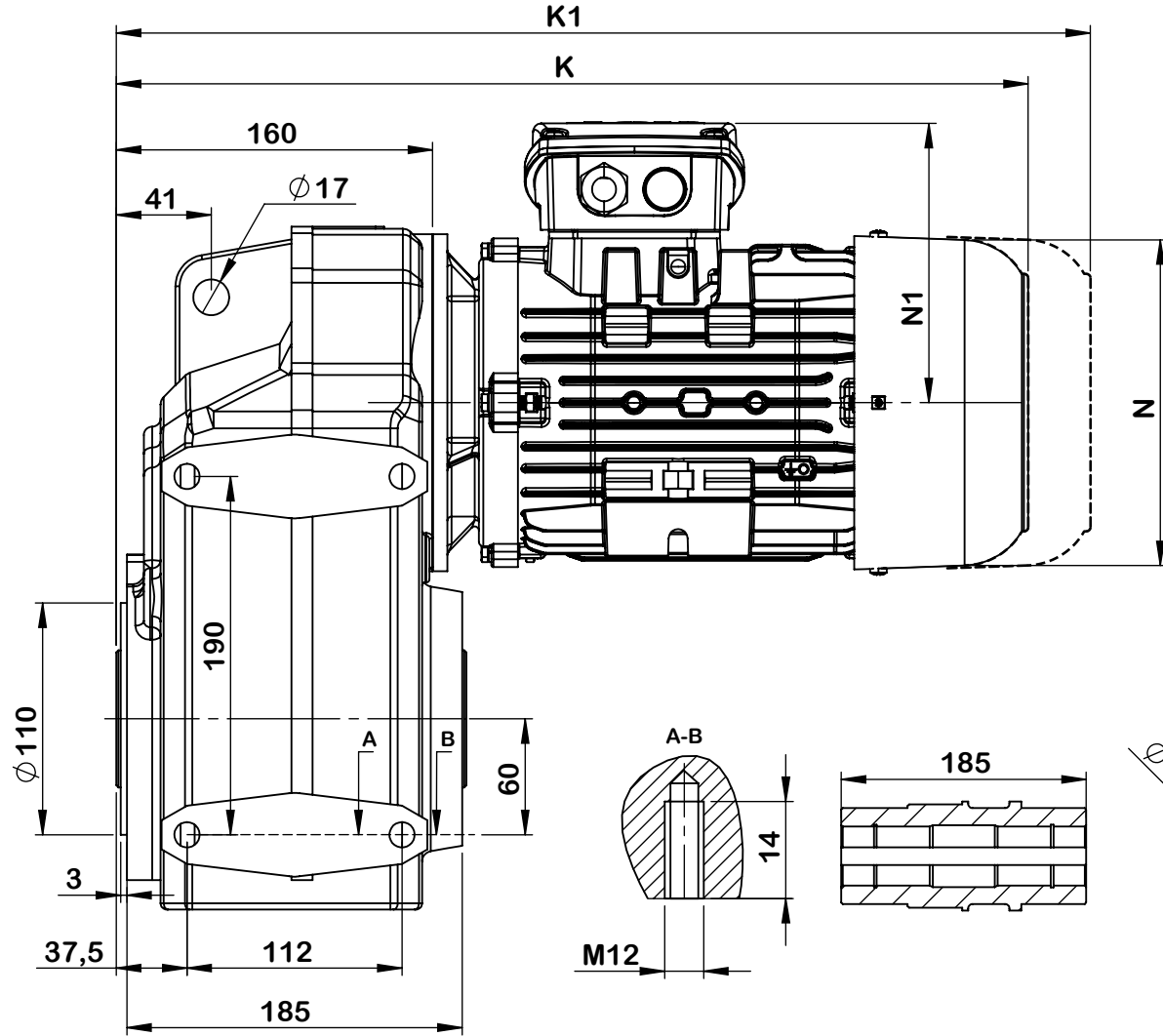

	MOTOR	K	K1	N	N1
D 372 D 373	71M	400,5	480,5	140	112
	80M	404,5	494,5	158,5	130
	90S	467,5	567,5	178	138
	90L	499,5	599,5	178	138
	100S	503	608	197	149,5
	100L	540,5	645,5	197	149,5
	112M	522	632	219	165,5
	132S	571,5	706,5	258,5	186,5
	132M	609,5	744,5	258,5	186,5

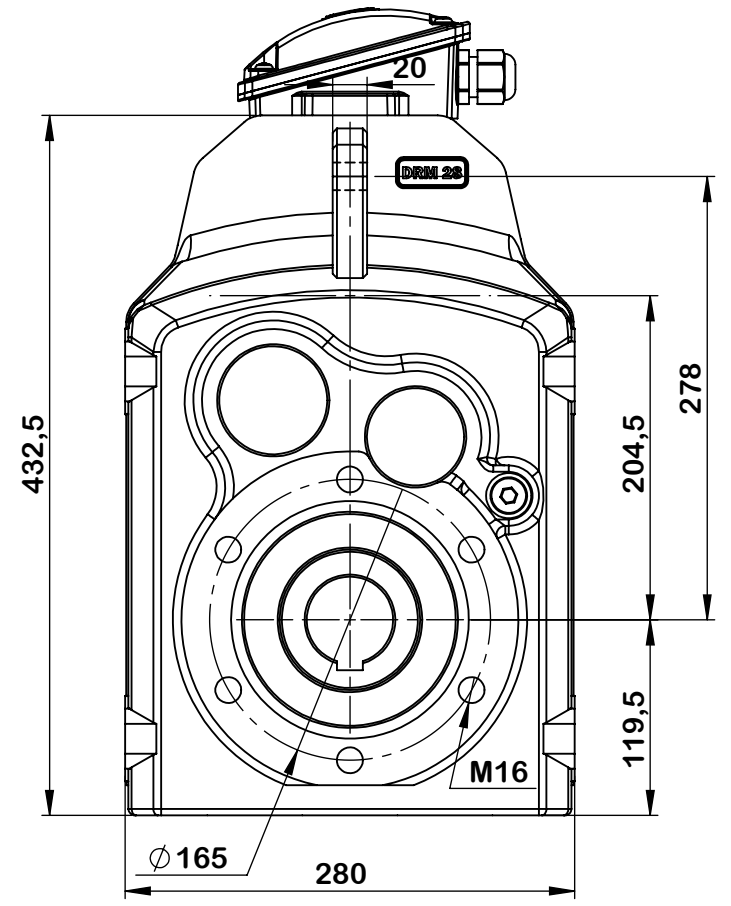
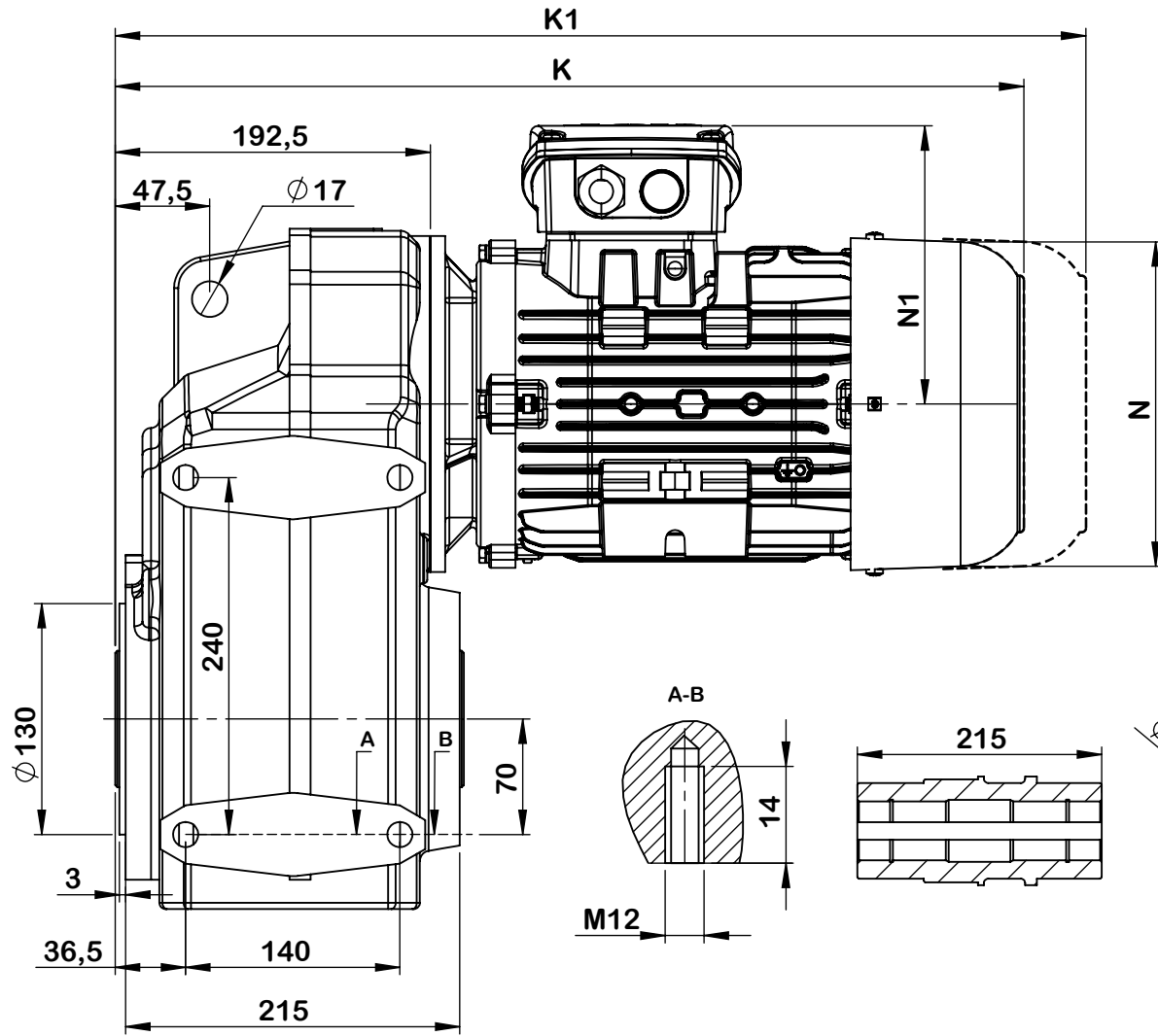

	MOTOR	K	K1	N	N1
<b>D 472</b> <b>D 473</b>	80M	434	524	158,5	130
	90S	500	600	178	138
	90L	532	632	178	138
	100S	535,5	640,5	197	149,5
	100L	573	678	197	149,5
	112M	556	666	219	165,5
	132S	602	737	258,5	186,5
	132M	640	775	258,5	186,5

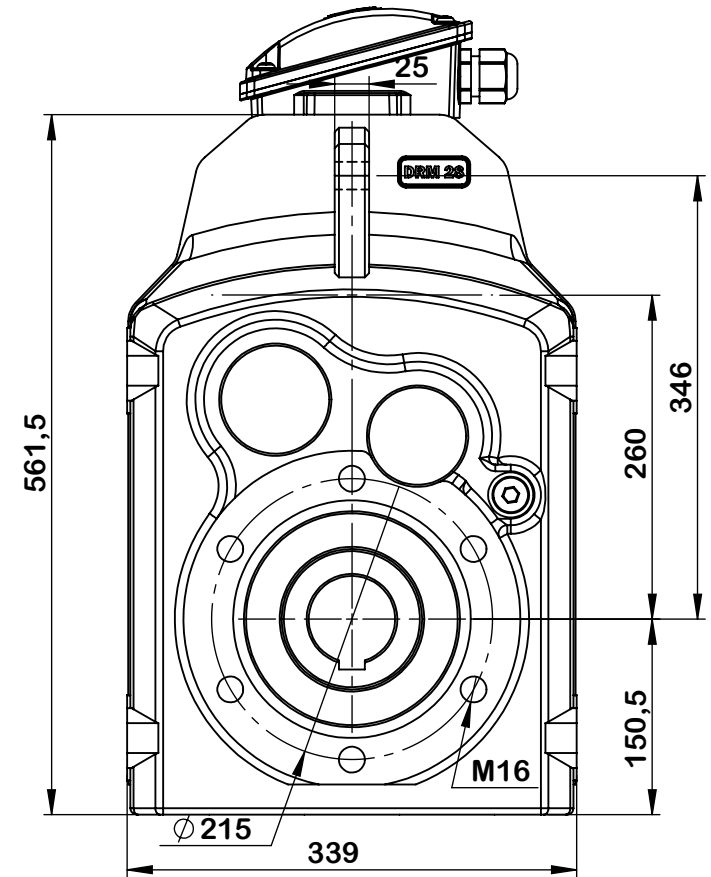
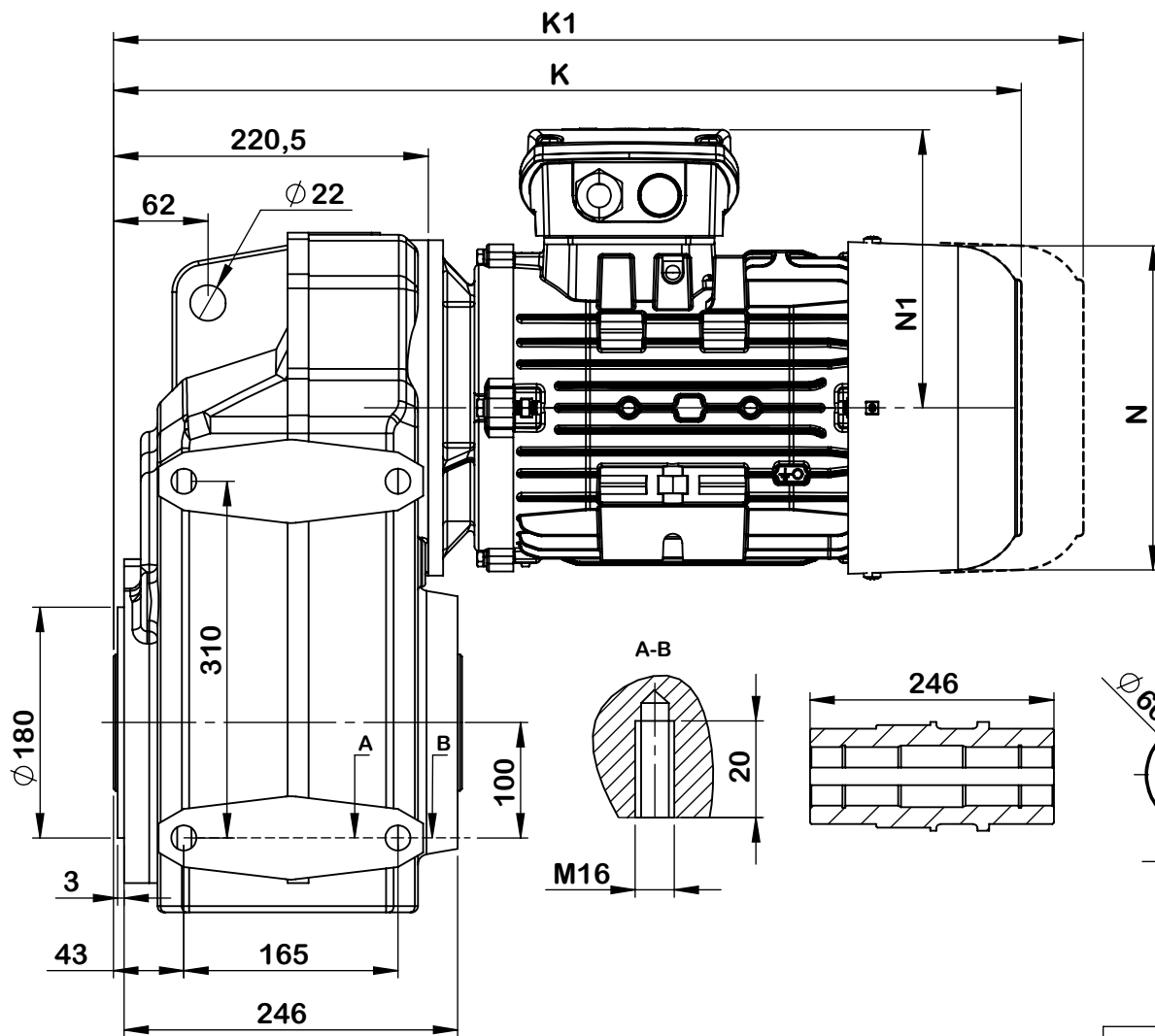

	MOTOR	K	K1	N	N1
<b>D 572</b> <b>D 573</b>	90S	523,5	623,5	178	138
	90L	555,5	655,5	178	138
	100S	563,5	668,5	197	149,5
	100L	601	706	197	149,5
	112M	584	694	219	165,5
	132S	630	765	258,5	186,5
	132M	668	803	258,5	186,5
	160M	735	895	308	238
	160L	778,5	938,5	308	238
	180M	877,5	1007,5	347,5	258
	180L	877,5	1007,5	347,5	258

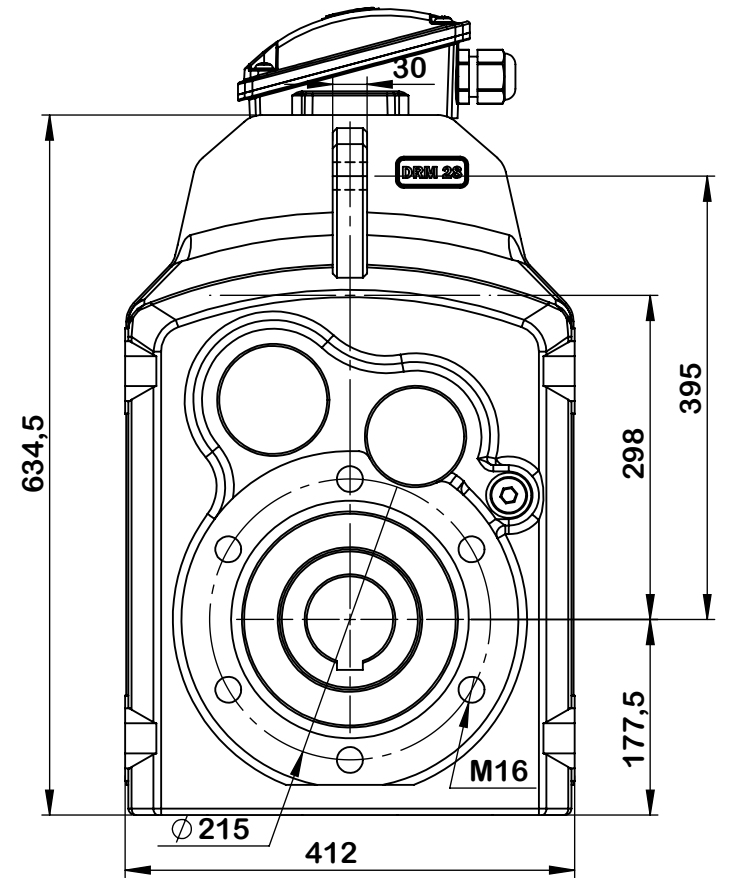
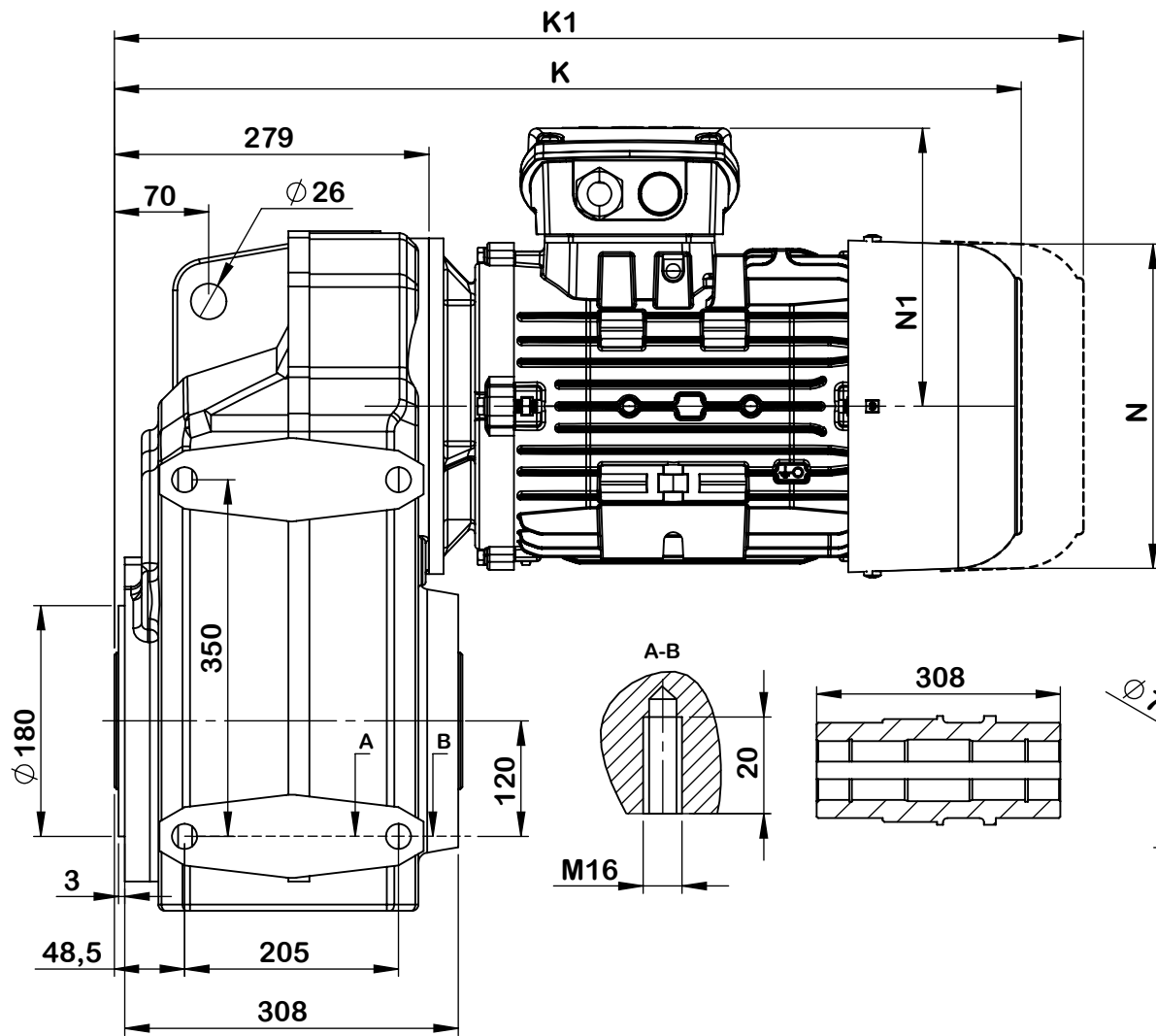

	MOTOR	K	K1	N	N1
<b>D 672</b> <b>D 673</b>	100S	613	718	197	149,5
	100L	650,5	755,5	197	149,5
	112M	646	756	219	165,5
	132S	688,5	823,5	258,5	186,5
	132M	726,5	861,5	258,5	186,5
	160M	793,5	953,5	308	238
	160L	837	997	308	238
	180M	936	1066	347,5	258
	180L	936	1066	347,5	258
	200L	1001	1141	390	290

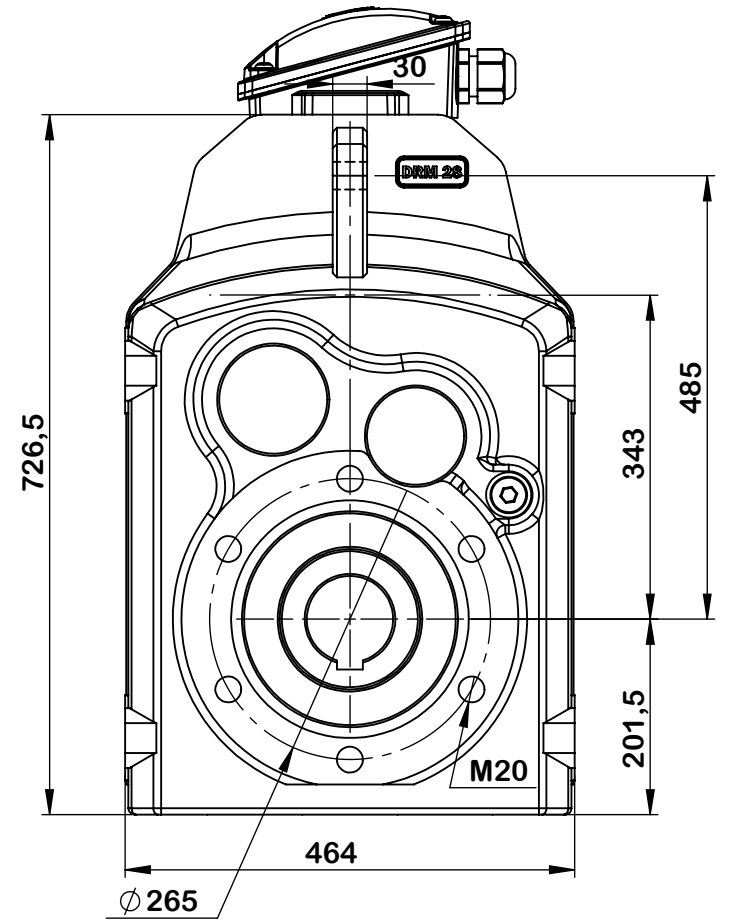
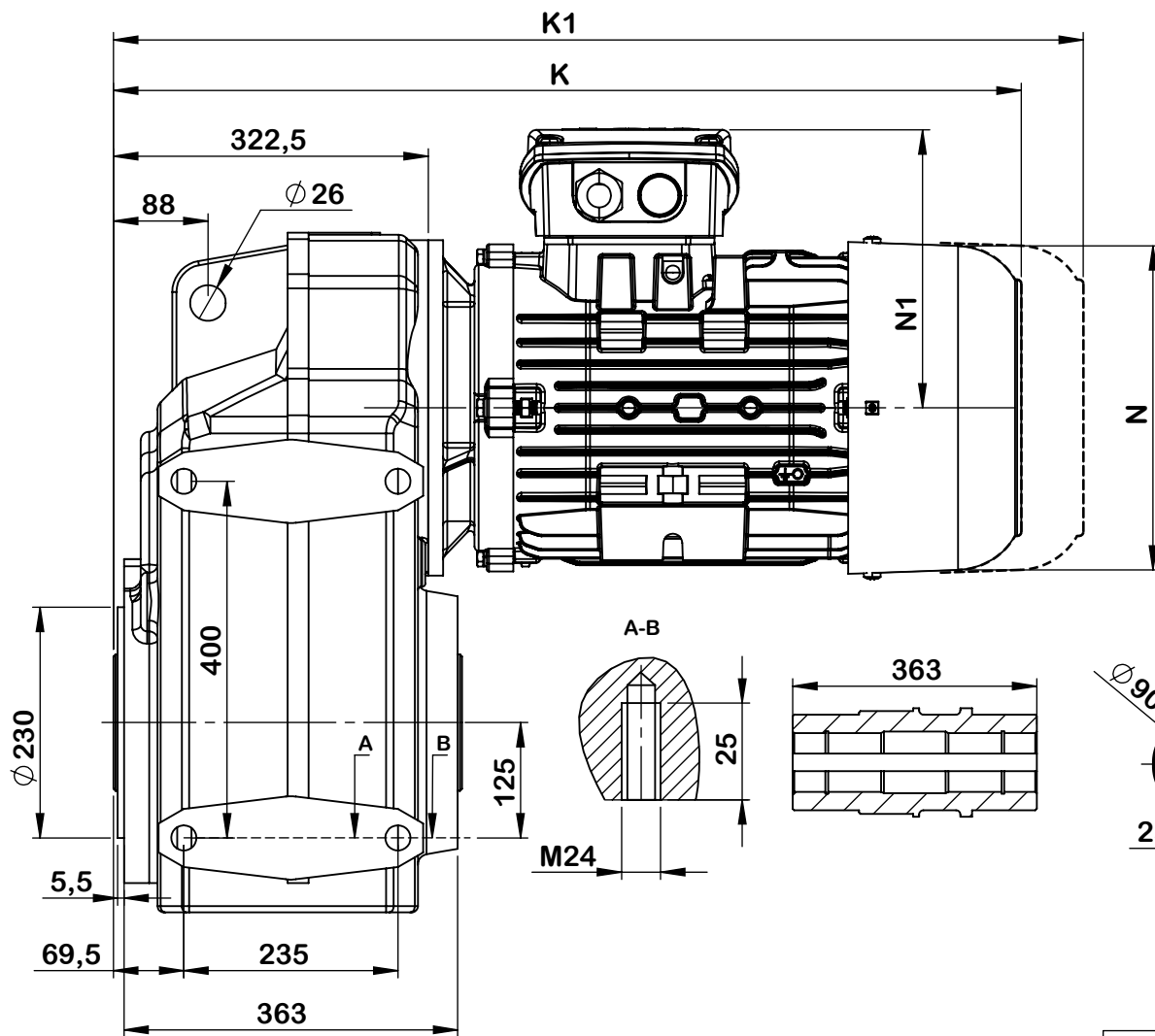

	MOTOR	K	K1	N	N1
D 772 D 773	112M	689	799	219	165,5
	132S	732,5	867,5	258,5	186,5
	132M	770,5	905,5	258,5	186,5
	160M	839	999	308	238
	160L	882,5	1042,5	308	238
	180M	979,5	1109,5	347,5	258
	180L	979,5	1109,5	347,5	258
	200L	1045	1185	390	290
	225S	1040,5	1240,5	434,5	300,5
	225M	1040,5	1240,5	434,5	301