

	MOTOR	K	K1	N	N1
<b>ES 30</b>	56M/B5	277,5	-	111	98
	56M/B14	262,5	-	111	98
	63M/B5	275,5	345,5	125	103
	63M/B14	275,5	345,5	125	103

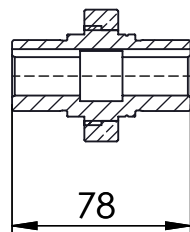

	MOTOR	K	K1	N	N1
<b>ES 40</b>	63M/B5	300,5	370,5	125	103
	63M/B14	300,5	370,5	125	103
	71M/B5	346,5	426,5	140	112
	71M/B14	346,5	426,5	140	112

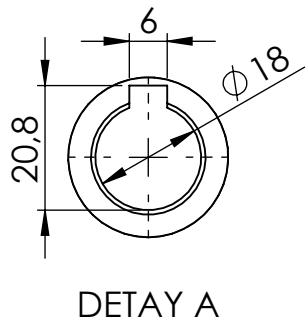
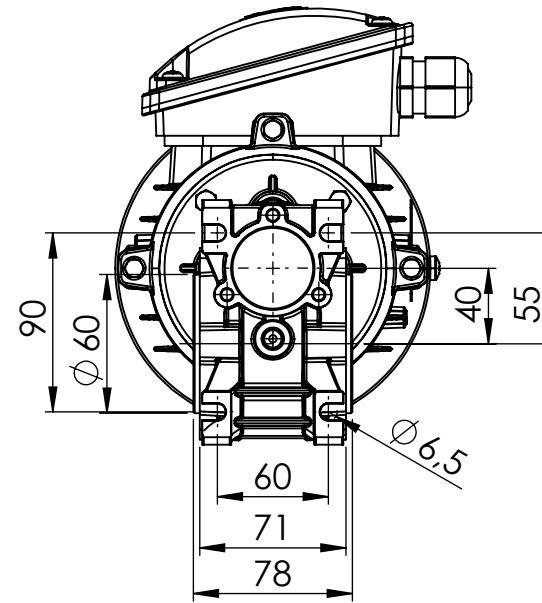
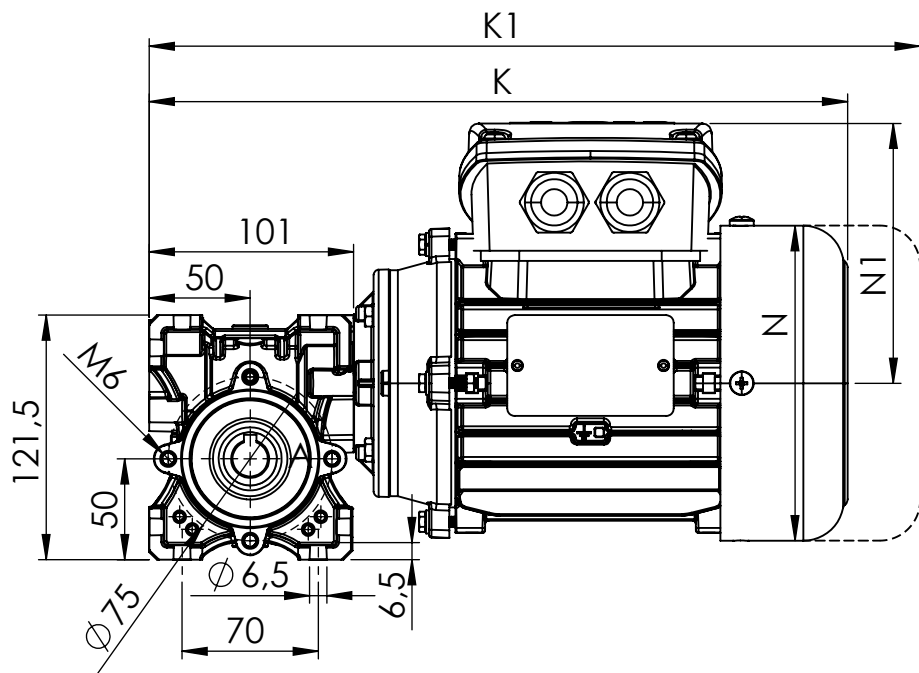
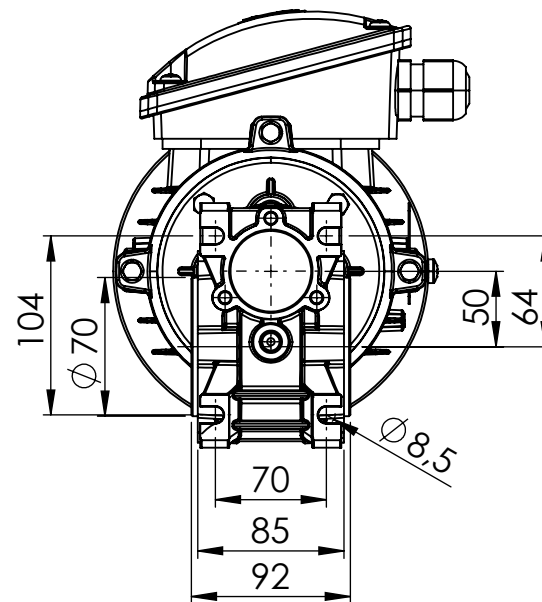
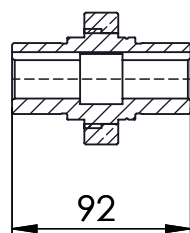
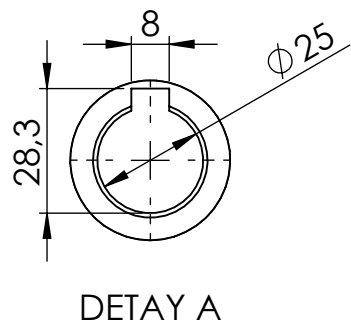
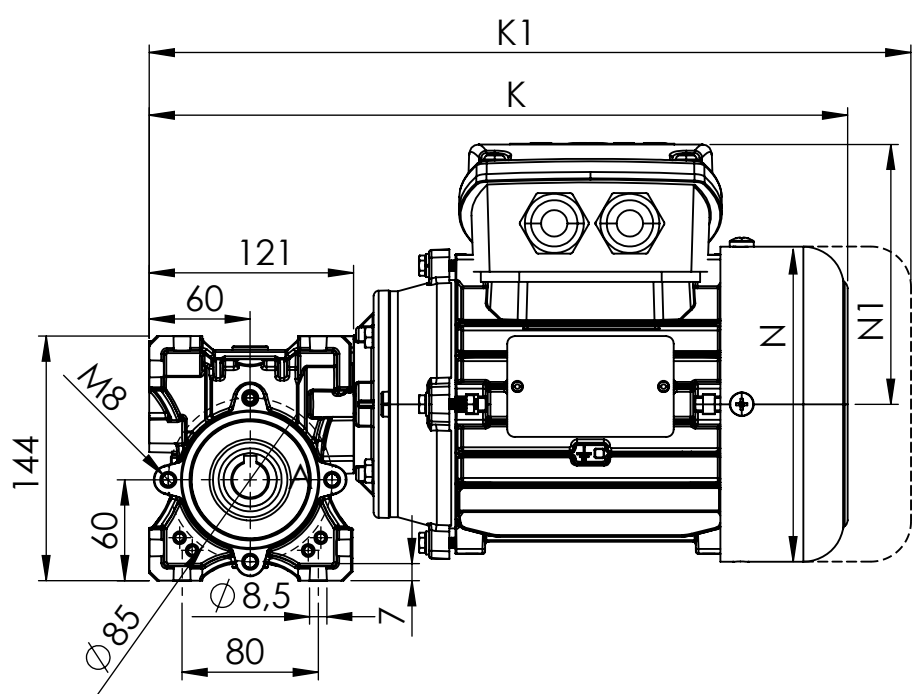

	MOTOR	K	K1	N	N1
<b>ES 50</b>	71M/B5	368,5	448,5	140	112
	71M/B14	366,5	446,5	140	112
	80M/B5	408,5	498,5	158,5	130
	80M/B14	406,5	496,5	158,5	130

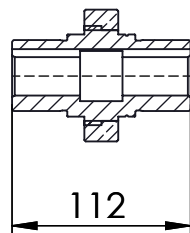
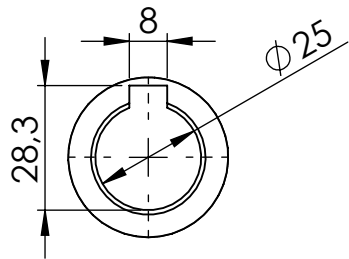
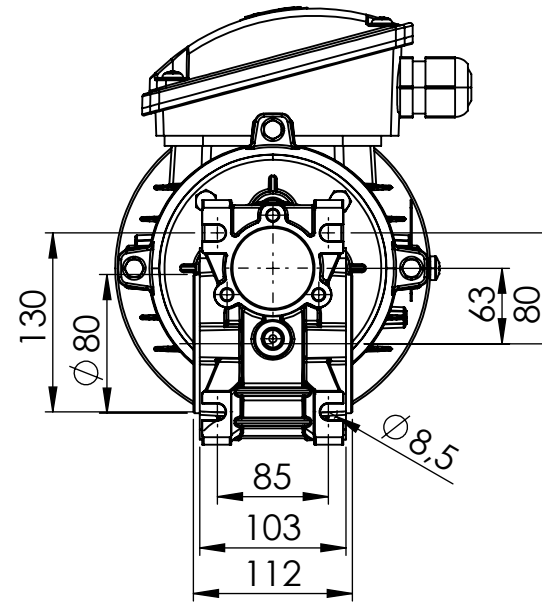
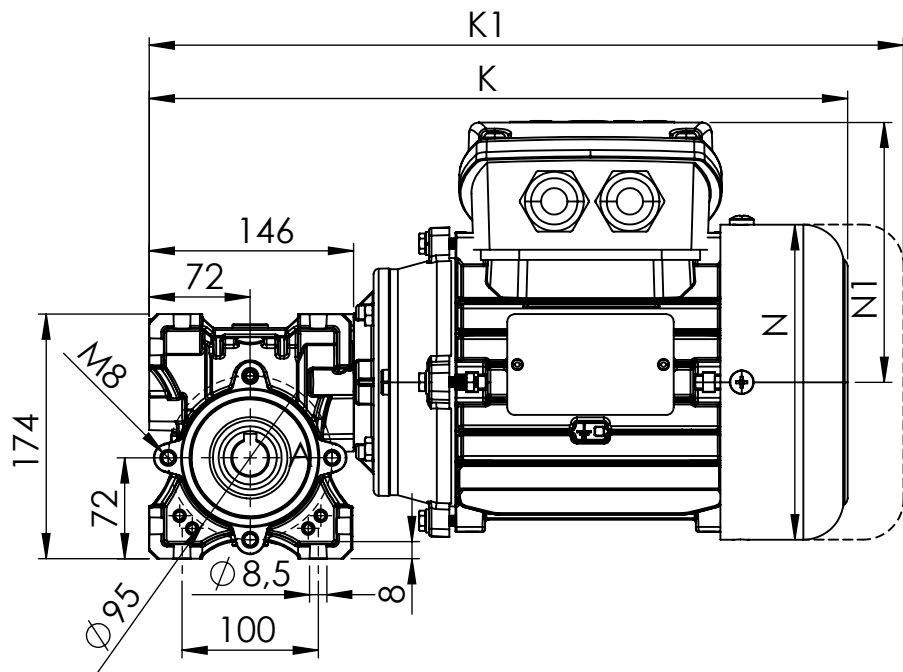

	MOTOR	K	K1	N	N1
<b>ES 63</b>	71M/B5	393,5	473,5	140	112
	71M/B14	393,5	473,5	140	112
	80M/B5	433,5	523,5	158,5	130
	80M/B14	434	524	158,5	130
	90S/B5	455	555	178	138
	90S/B14	455	555	178	138
	90L/B5	487	587	178	138
	90L/B14	487	587	178	138

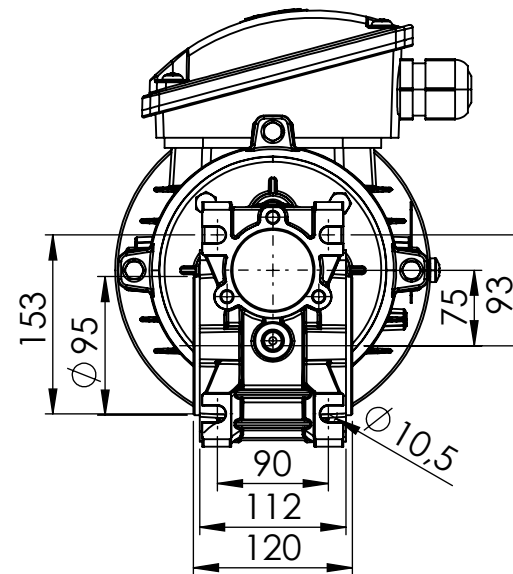
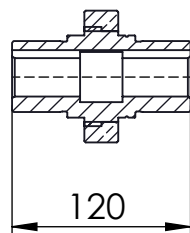
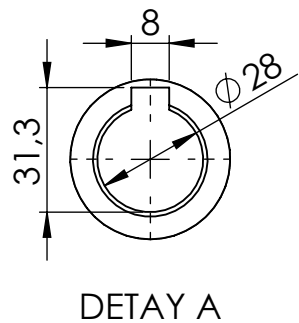
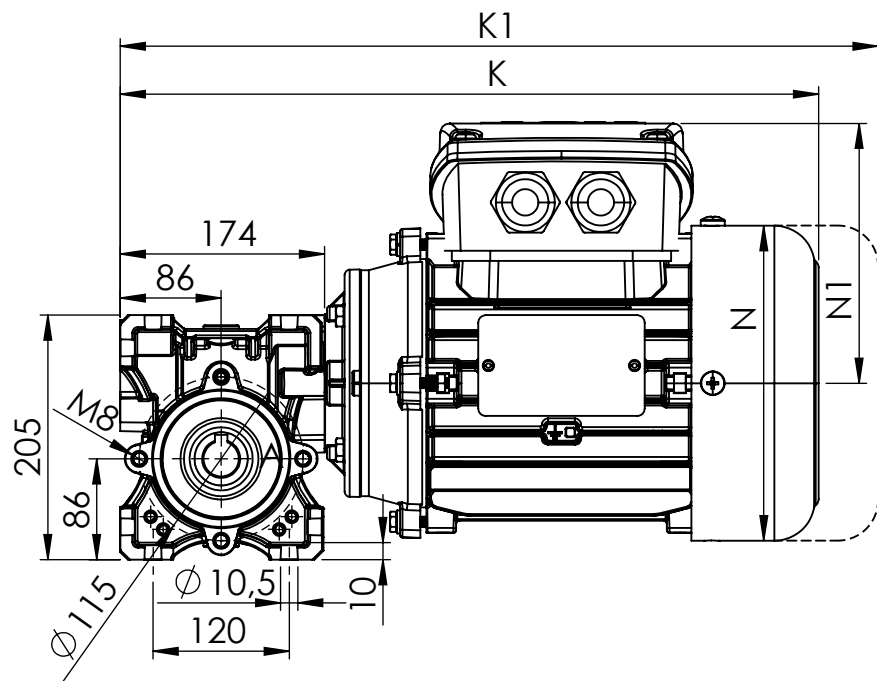

ES 75	MOTOR	K	K1	N	N1
	80M/B5	464,5	554,5	158,5	130
	80M/B14	464,5	554,5	158,5	130
	90S/B5	486	586	178	138
	90S/B14	486	586	178	138
	90L/B5	518	618	178	138
	90L/B14	518	618	178	138
	100S/B5	510,5	615,5	197	149,5
	100S/B14	510,5	615,5	197	149,5
	100L/B5	548	653	197	152,5
	100L/B14	548	653	197	152,5
	112M/B5	560,5	670,5	219	166,5
112M/B14	538	648	219	166,5	

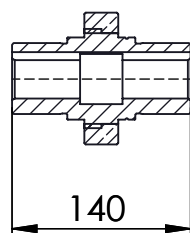
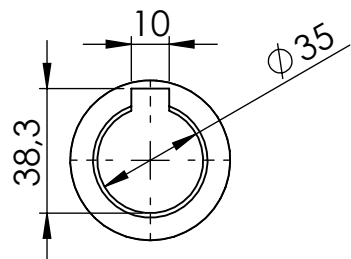
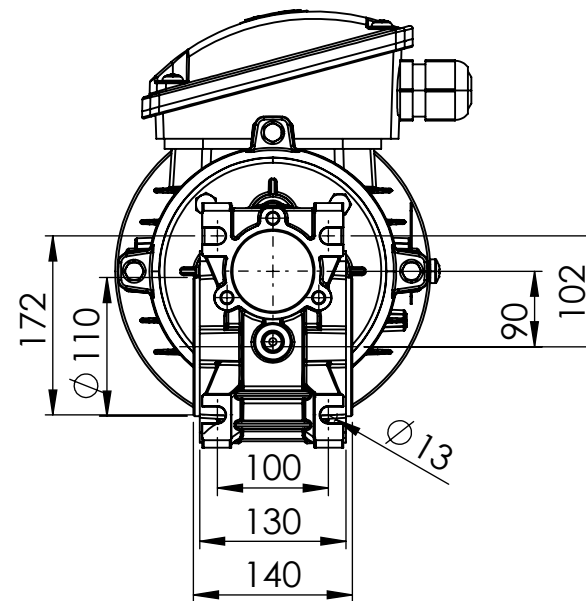
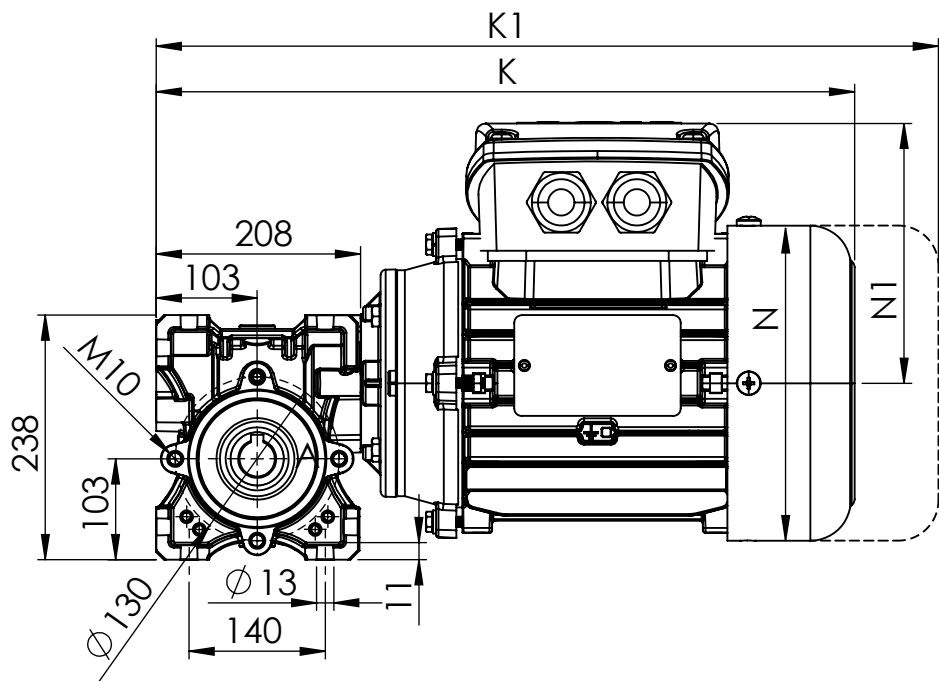

DETAY A

	MOTOR	K	K1	N	N1
<b>ES 90</b>	80M/B5	500	590	158,5	130
	80M/B14	507	597	158,5	130
	90S/B5	521,5	621,5	178	138
	90S/B14	521,5	621,5	178	138
	90L/B5	553,5	653,5	178	138
	90L/B14	553,5	653,5	178	138
	100S/B5	546	651	197	149,5
	100S/B14	546	651	197	149,5
	100L/B5	583,5	688,5	197	152,5
	100L/B14	583,5	688,5	197	152,5
	112M/B5	594,5	704,5	219	166,5
	112M/B14	572	682	219	166,5

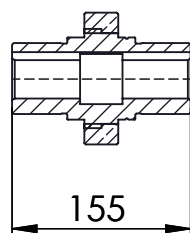
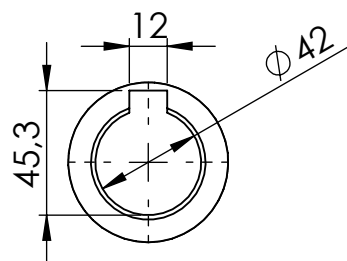
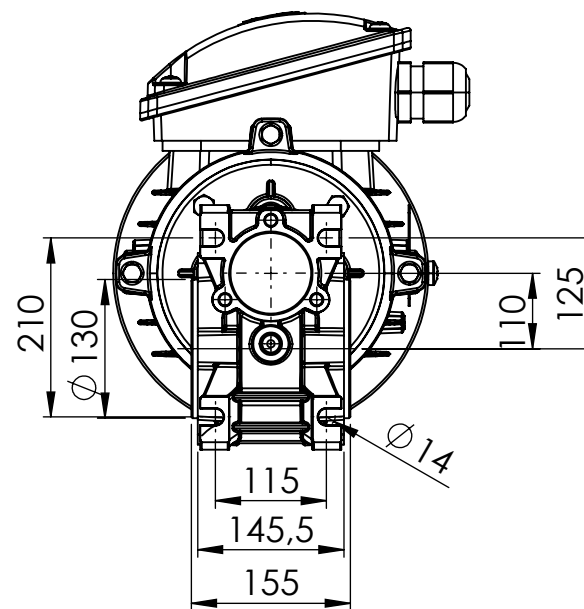
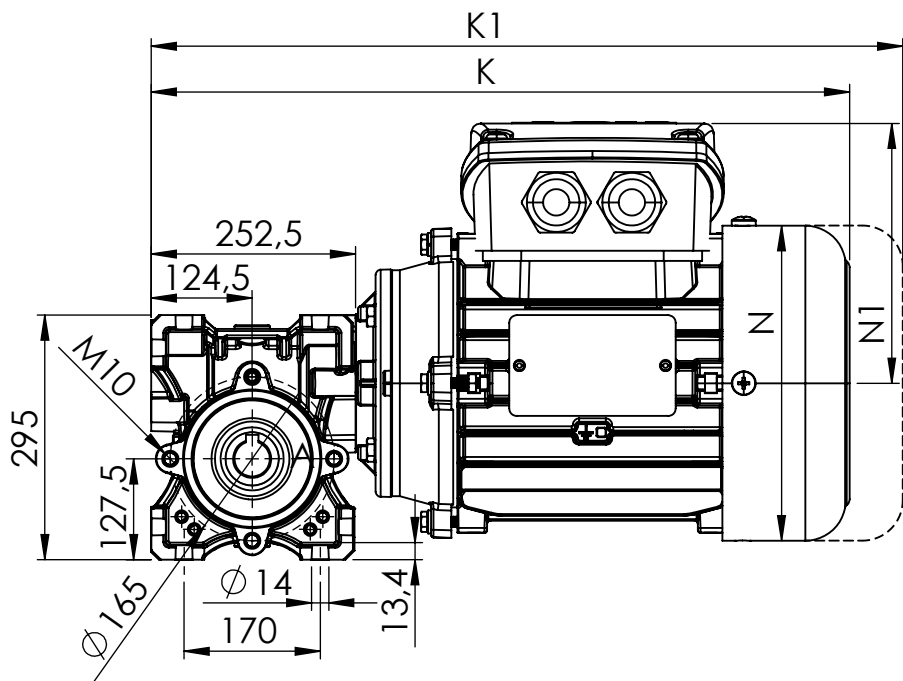

	MOTOR	K	K1	N	N1
<b>ES 110</b>	90S/B5	577,5	677,5	178	138
	90S/B14	577,5	677,5	178	138
	90L/B5	609,5	709,5	178	138
	90L/B14	609,5	709,5	178	138
	100S/B5	600	705	197	149,5
	100S/B14	602	707	197	149,5
	100L/B5	637,5	742,5	197	152,5
	100L/B14	639,5	744,5	197	152,5
	112M/B5	650	760	219	166,5
	112M/B14	629,5	739,5	219	166,5
	132S/B5	687	822	258,5	187,5
	132S/B14	689	824	258,5	187,5
	132M/B5	725,5	860,5	258,5	187,5
	132M/B14	727,5	862,5	258,5	187,5

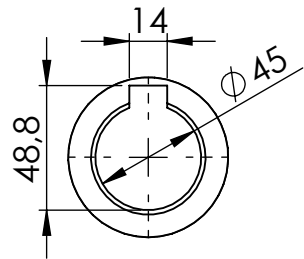
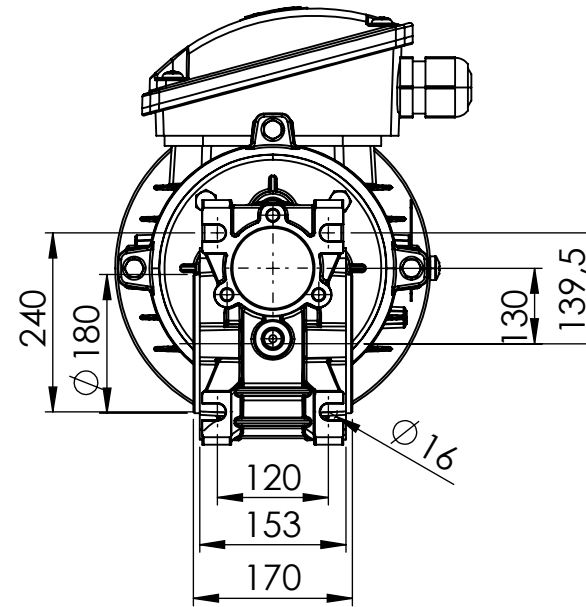
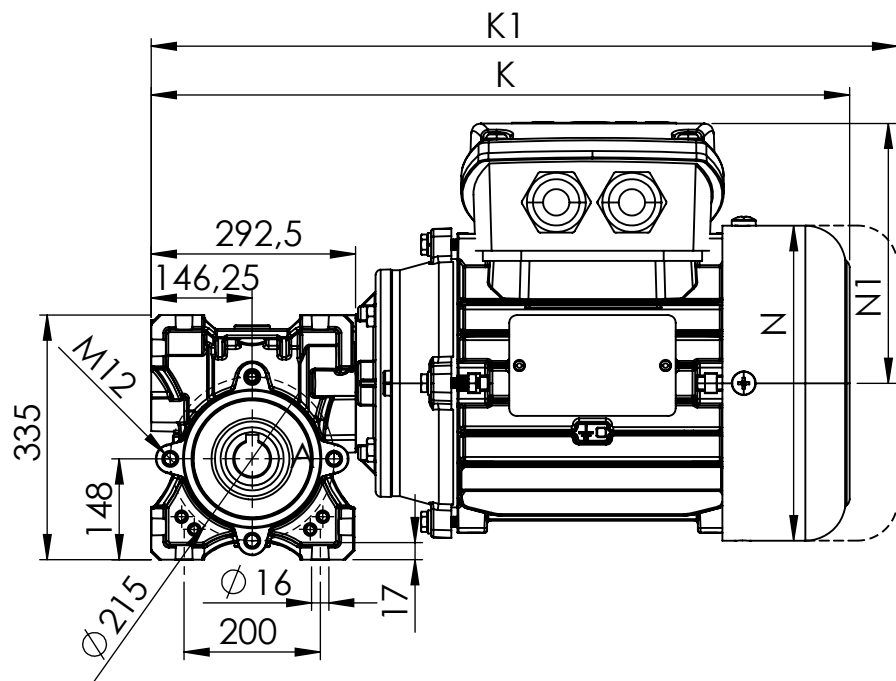

DETAY A

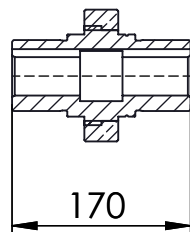

170

ES 130	MOTOR	K	K1	N	N1
	90S/B5	617,5	717,5	178	138
	90S/B14	617,5	717,5	178	138
	90L/B5	649,5	749,5	178	138
	90L/B14	649,5	749,5	178	138
	100S/B5	640	745	197	149,5
	100S/B14	642	747	197	149,5
	100L/B5	677,5	782,5	197	152,5
	100L/B14	679,5	784,5	197	152,5
	112M/B5	690	800	219	166,5
	112M/B14	691,5	801,5	219	166,5
	132S/B5	727	862	258,5	187,5
	132S/B14	729	864	258,5	187,5
	132M/B5	765,5	900,5	258,5	187,5
132M/B14	767,5	902,5	258,5	187,5	



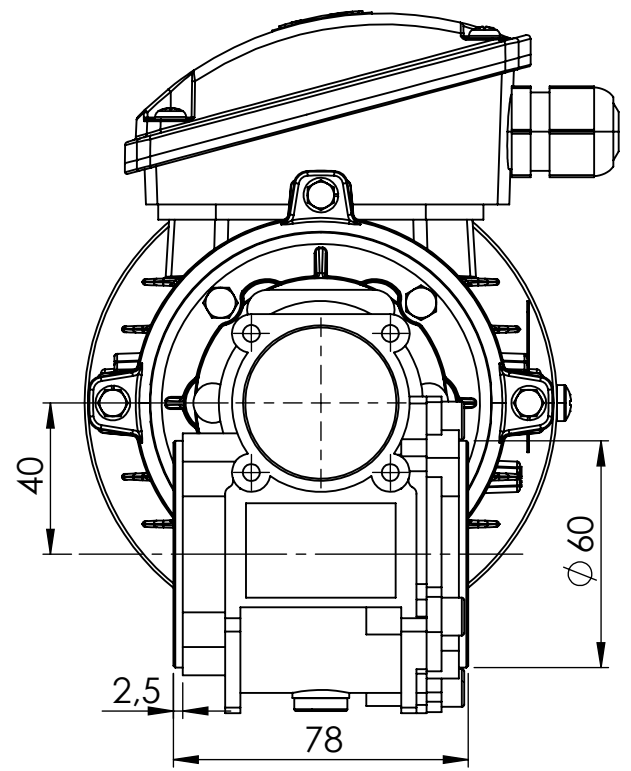
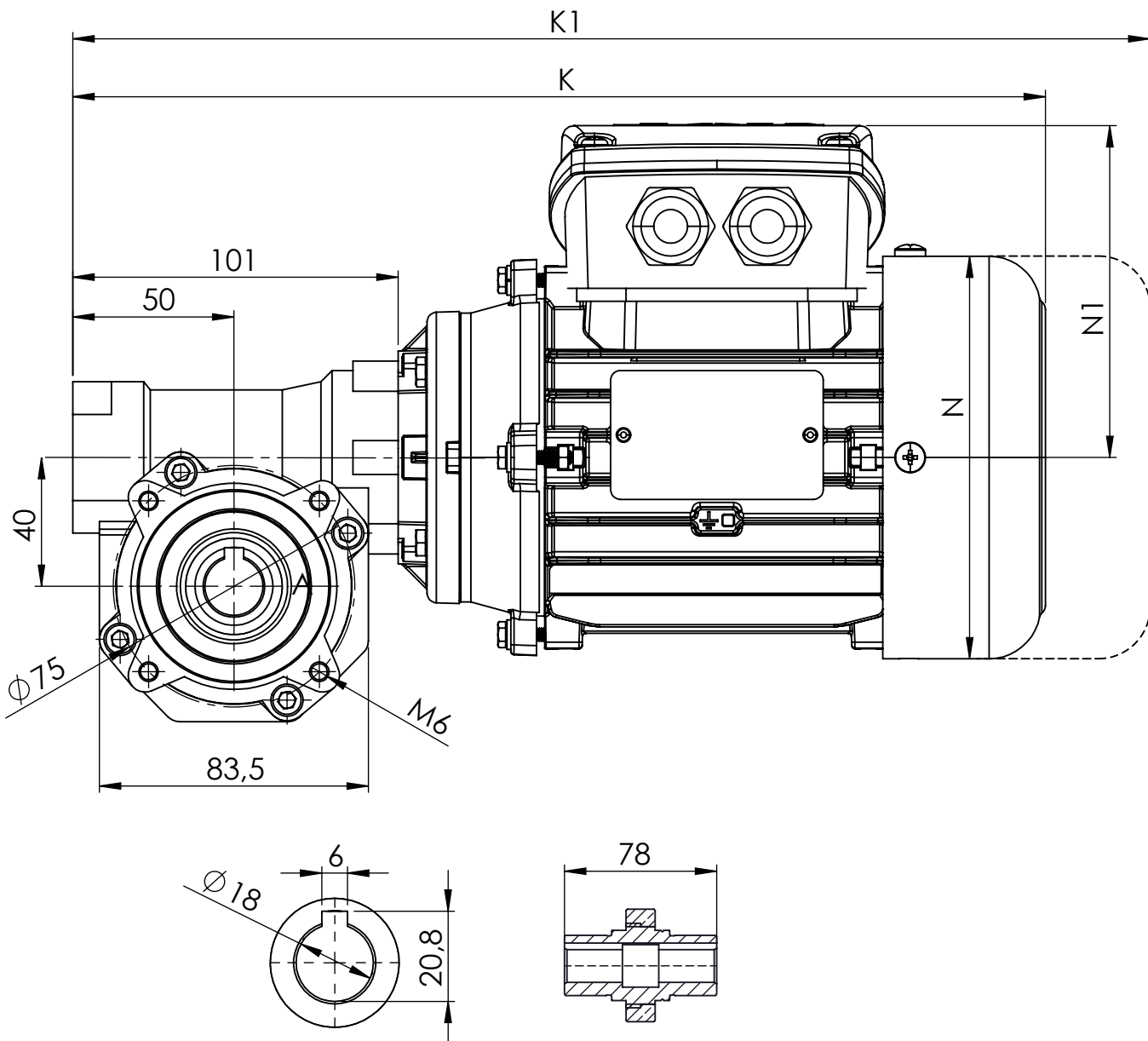

	MOTOR	K	K1	N	N1
EW 40	63M/B5	300,5	370,5	125	103
	63M/B14	302	372	125	103
	71M/B5	346,5	426,5	140	112
	71M/B14	346,5	426,5	140	112

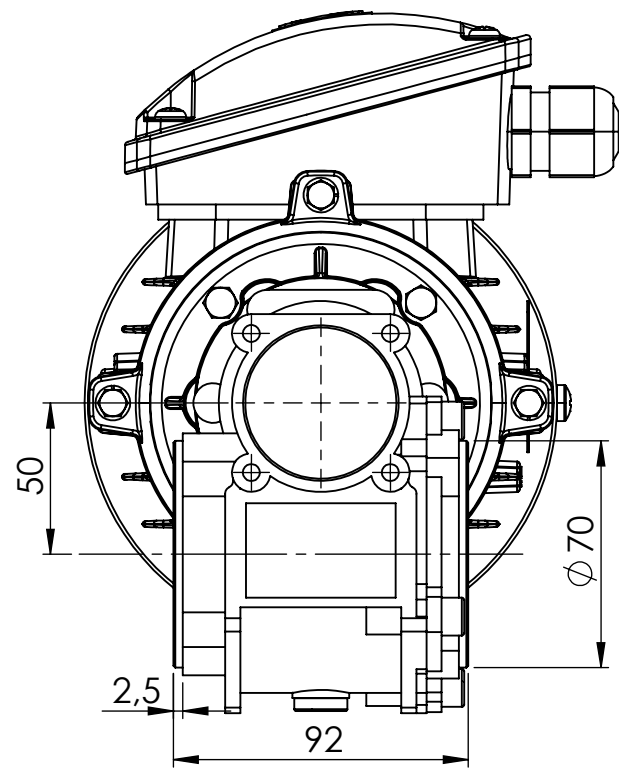
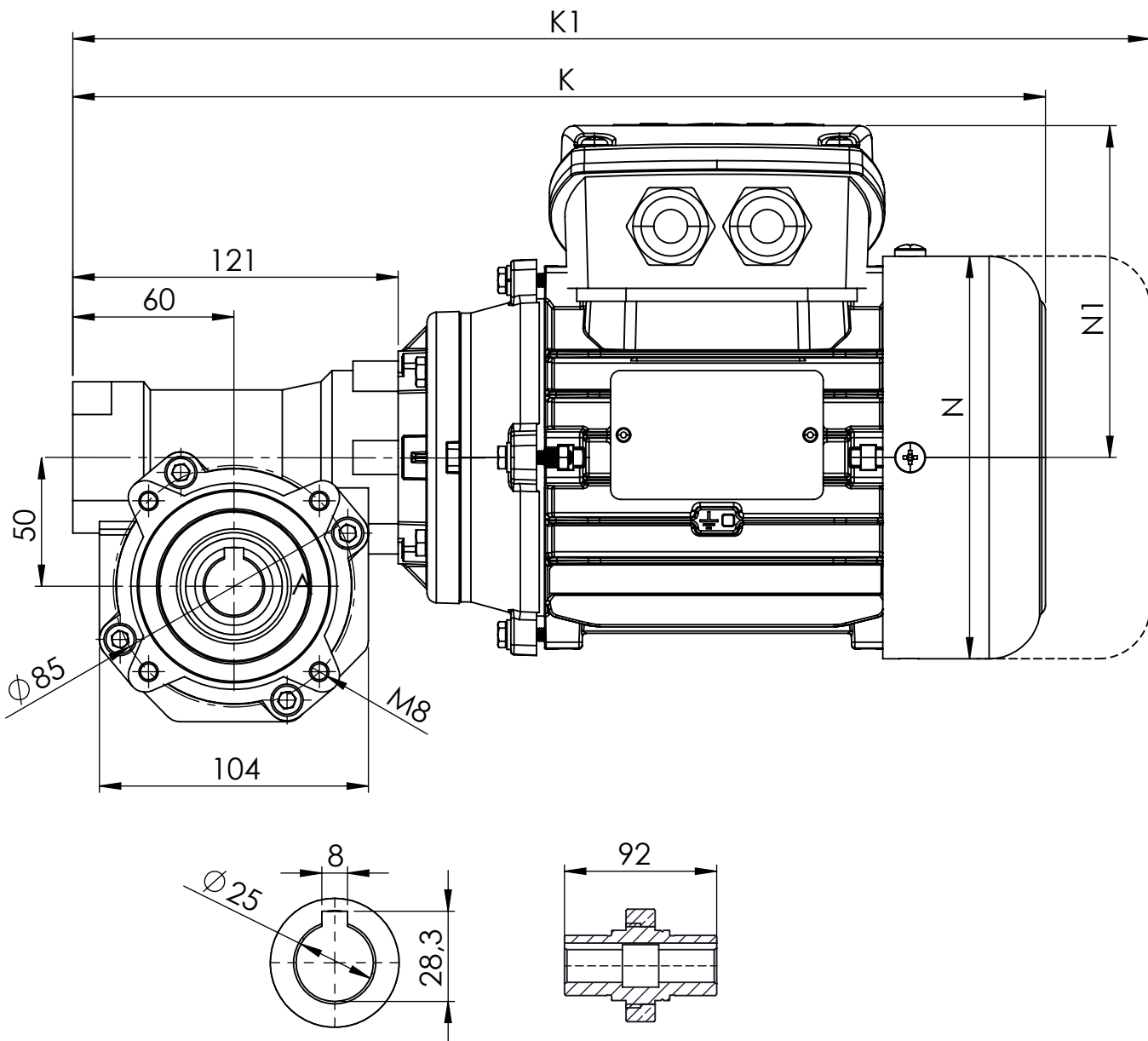

	MOTOR	K	K1	N	N1
EW 50	71M/B5	368,5	448,5	140	112
	71M/B14	366,5	446,5	140	112
	80M/B5	408,5	498,5	158,5	130
	80M/B14	406,5	496,5	158,5	130

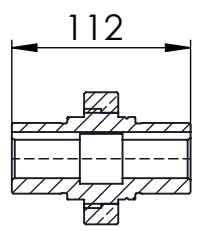
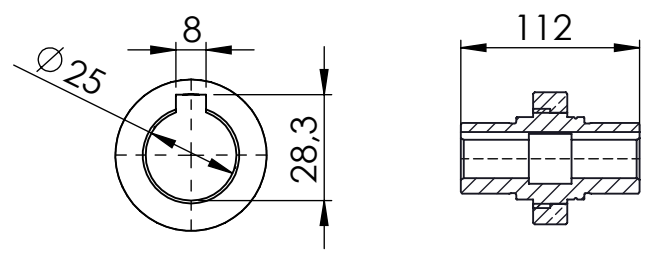
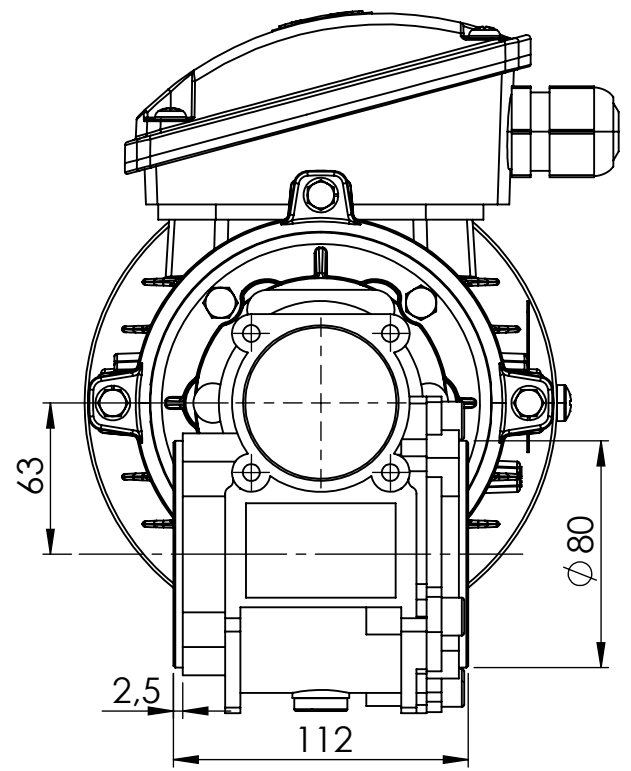
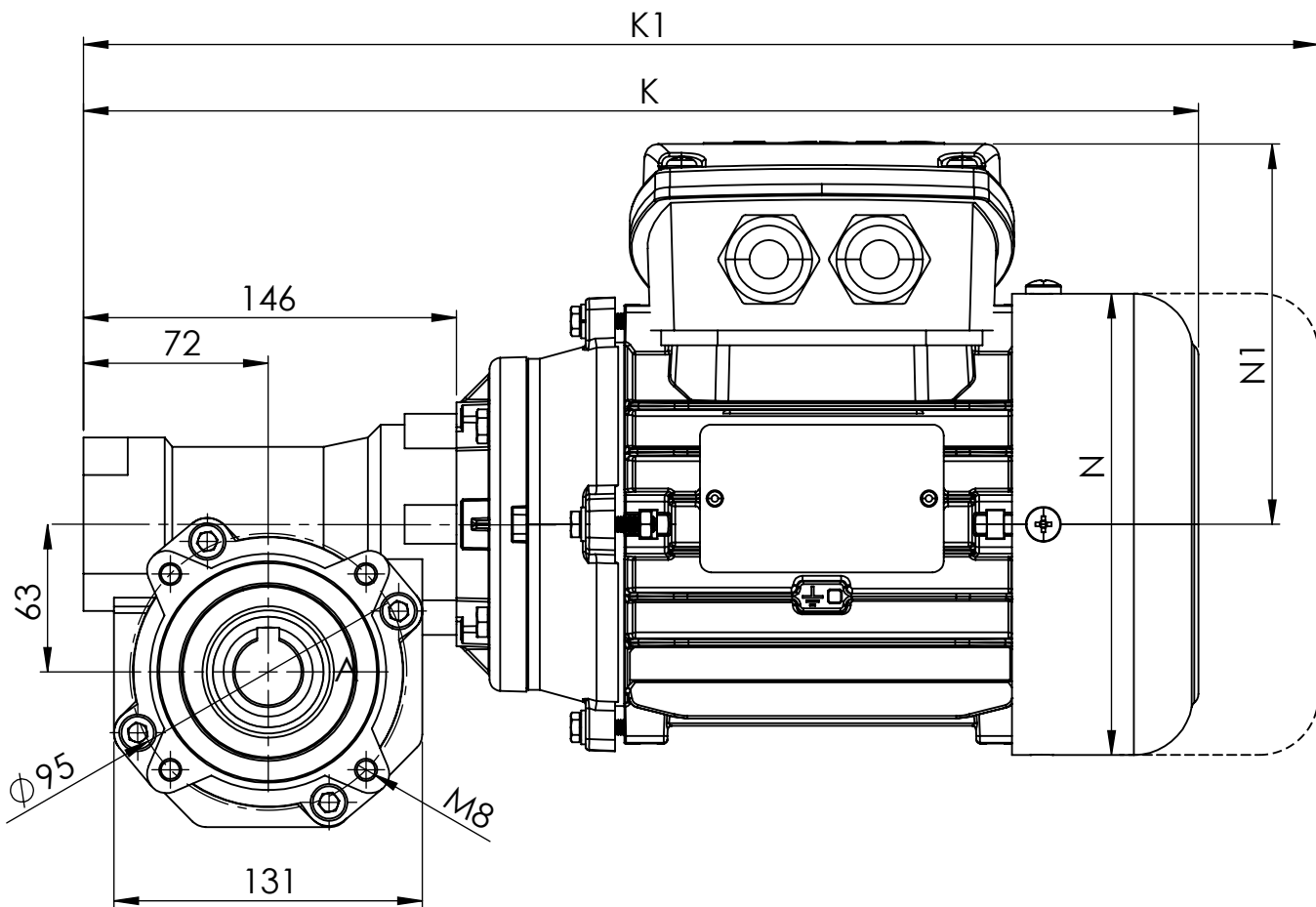

EW 63	MOTOR	K	K1	N	N1
	71M/B5	393,5	473,5	140	112
	71M/B14	393,5	473,5	140	112
	80M/B5	433,5	523,5	158,5	130
	80M/B14	434	524	158,5	130
	90S/B5	455	555	178	138
	90S/B14	455	555	178	138
	90L/B5	487	587	178	138
	90L/B14	487	587	178	138